

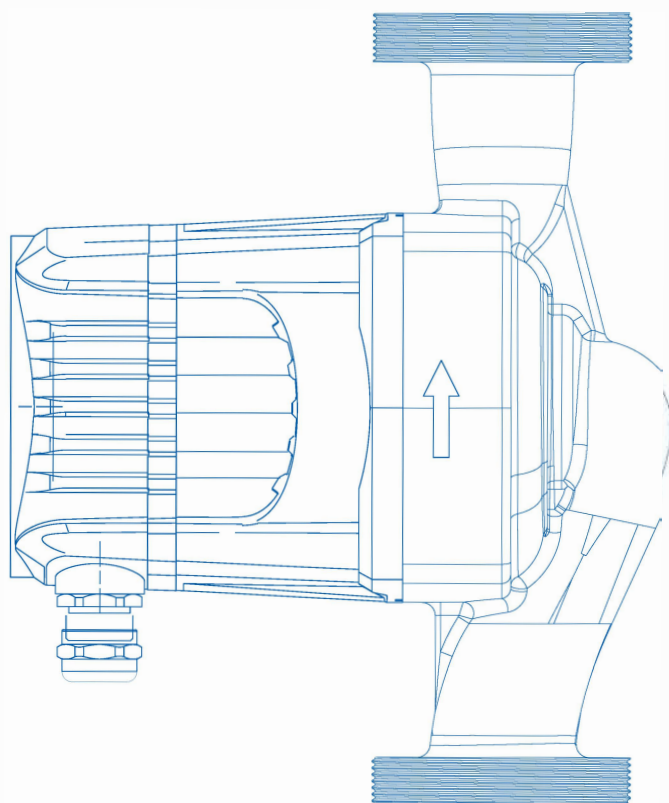

iNERGY®

确认版面 关巧霞/郑婷婷 2024. 7. 8
Intelligent Auto-Adaptive permanent
magnet variable frequency shielded
circulating pump



12 MONTHES
GUARANTEE PERIOD

INSTALLATION & OPERATION
INSTRUCTIONS

INTELLIGENT SELF-ADAPTION PERMANENT MAGNET VARIABLE FREQUENCY SHIELDED CIRCULATING PUMP

DIRECTORY

1

OVERVIEW

Model Description	4
Performance range	5

2

APPLICATION

Pumped liquid	6/7
Control of heating systems	8
Scale Mode run	8 9
Control advantage	9
Night mode	10

3

STRUCTURE

Sectional view	11
Motor and control box	12
fault indication	13

4

INSTALLATION AND STARTUP

Install	14	System pressure	15
Power cord description		liquid temperature	16
Communication Line Description		Inlet pressure	
Electric data	15	Maintenance	17
Firing		Troubleshooting	18

5

PERFORMANCE ORIENTED CURVE

Parameter list	19
----------------	----

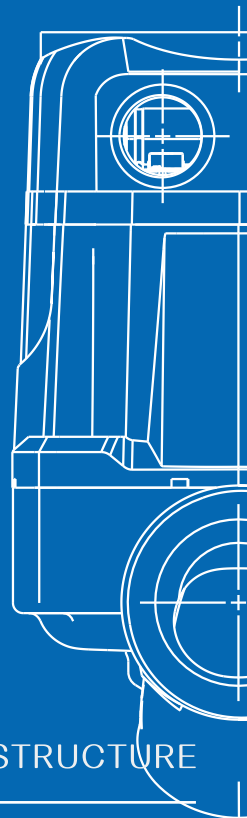

Dear users:

Thank you very much for choosing our pump intelligent adaptive permanent magnet frequency shield circulating pump, we will continue as always To provide you with quality products and services. In order to ensure that you can use it correctly and safely, In order to ensure that you can use it the pump correctly and safely, please readthis manual carefully before use.

In the process of your use of this product, if you have any questions, please call our service phone, we will be very happy to answer your questions.

I hope you can fill in the 《after-sales service Warranty Card》 carefully to ensure that you can enjoy the intimate service provided by our company.

Thank you again for choosing our pump Technology series products.

WARNING

- ★ The circulating pump must be reliably grounded before use, and the leakage protection device should be installed;
- ★ The pump temperature is high during operation, the driver module serves as cooling radiator, temperature on surface is maximumly 55°C
- ★ It is strictly prohibited to run the circulating pump without water, pay attention to exhousing the air in the system;
- ★ In order to prevent electric shock, the power supply should be cut off before servicing or cleaning the circulating pump;

WARNING

IT IS STRICTLY FORBIDDEN TO RUN THE PUMP WITHOUT WATER OR WITHOUT LOADING

- ★ Circulating pump must be connected to pipes with water, otherwise it would be burned.
- ★ It is strictly prohibited to connect the cable under energized condition, otherwise there is danger of electric shock.



WARM REMINDER

In order to get the best user experience of this product, some changes without prior notice would be applied on performance and functions of the pump, thank you for understanding.performance and function of the product may change without prior notice.

TYPE DESCRIPTION

Intelligent auto-adaptive permanent magnet variable frequency shielded circulating pump is a full range of small intelligent adaptive permanent magnet frequency conversion shielding circulating pumps with the following features:

- **AUTO ADAPT** The auto-adapt control function is applicable to most applications.
- **Built-in proportional pressure control** adjusts pump performance according to actual system requirements.
- **Automatic speed reduction at night (optional).**
- **Displays actual wattage or flow m³/h.**
- **Rotor and special compact stator technology based on permanent magnet technology.**

				Pump base material
	Hvac pump		Frequency conversion	Plastic pump: P Brass pump body: BR Cast iron pump body: omit Stainless steel pump body: S
	25	80	180	
	Inlet and outlet pipe size: 25mm	Head: 8m	Pump body installation length: 180mm	

This pump is with an Energy Efficiency Index (EEI)<0.23, which is a good grade. Installing and using the pump can significantly reduce energy consumption while reducing the noise caused by balancing valve or similar device. It can also improve the control performance of the system.

Intelligent self-adaption permanent magnet variable frequency shielded circulating pump provides the following benefits:

Energy saving	Automatic proportional pressure control.
Flexible installation and use	Suitable for retrofitting existing systems.
Automatic speed reduction at night	Automatic speed reduction at night (optional).
Comfortable	Low operating noise.
Safe	Built-in pump electrical and thermal protection.
Friendly interface	Easy to set up and use.
Alarm function	Alarm signals can be displayed on the panel.
Warning,	Warning signals can be displayed on the panel.

Intelligent self-adaption permanent magnet variable frequency shielded circulating pump

- ★ This product adopts shielding structure in which motor stator and rotor are completely devided. The rotating parts are immersed in the conveying fluid, which plays a role in cooling the motor, as well as lubricating the bearings.
- ★ Exhaust screw to prevent motor from water shortage during commissioning.
- ★ Adapt to Low power standby automatically when all valves are closed of more energy efficient.
- ★ Motor windings are sealed to prevent coil damage caused by condensation. Suitable for hot and cold water systems.
- ★ The permanent magnet brushless DC variable frequency pump saves 80% energy compared to the fixed frequency pump.
- ★ Pressure and flow adaptive frequency conversion algorithm is used for on-demand transmission and distribution to meet the dynamic requirements of the temper ature control switch.
- ★ The shielded motor structure is smaller and quieter.

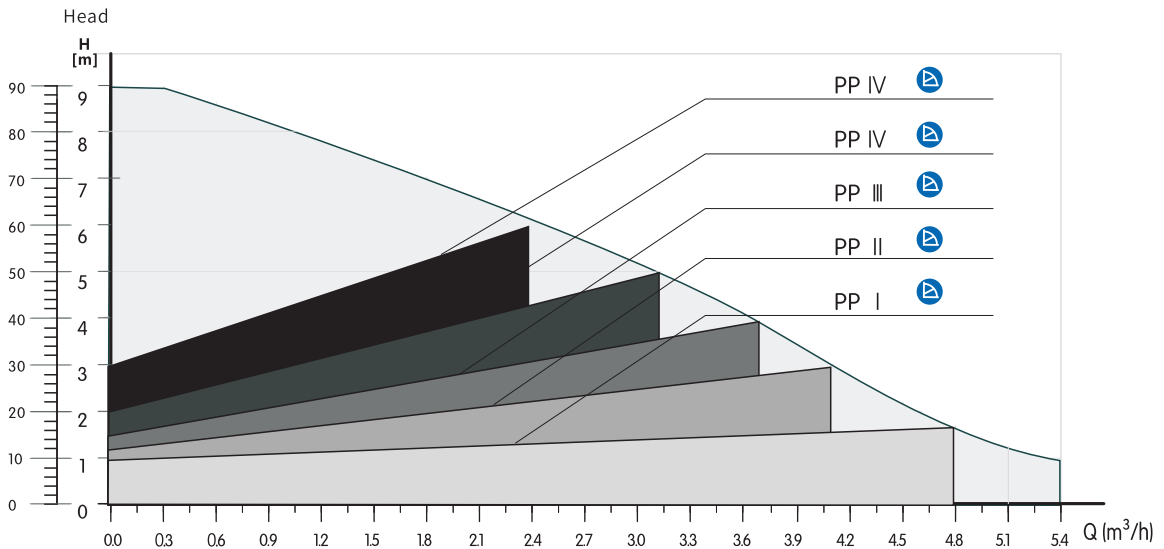

Figure 1 Scale performance range



This pump is designed to drive fluid circulation in heating and cooling systems as below:

- The system needs to match the actual demand by changing the pump operating point
- Flow and temperature changes in the system.
- A system that requires quiet operation with reduced noise.

The heating system can select the appropriate pump with the following information:

Rated parameter	Wall hanging furnace system	Heat pump (air energy) floor heating	Dual heating and cooling supply system	
	Δt 10°C	Δt 5°C	Primary system	Secondary system
Head/flow <small>(Recommended pipe diameter)</small>	Heat supply/area	Heat supply/area		
7 m /1.8 t <small>(not less than PPR40)</small>	20 kw /200m ²	10 kw /100m ² <small>Secondary system</small>	Lift within 7m Four pieces 10 kw The differential pressure bypass valve needs to be installed	The lift between the main engine and the water tank is less than 5 m , Eight pieces up to 20 kw Lift from tank to end within 5 m Within 100 m ² of fan coil Floor heating within 150 m ²
5m /3 t <small>(not less than PPR40)</small>	35kw /350m ²	17.5 kw /150m ² <small>Secondary system</small>		
3m /4.2 t <small>(not less than PPR40)</small>	52 kw /520m ²			

Note: The data is approximate value, we are not responsible for the wrong selection of pumps in the system.

This pump is ideal for:

In the existing system, when the required flow rate is reduced, the pump head is too high, and the newly installed system does not want to make With bypass valve or similar equipment, it is hoped that the circulating pump performance can be fully and automatically adjusted.

SYSTEM EXAMPLE

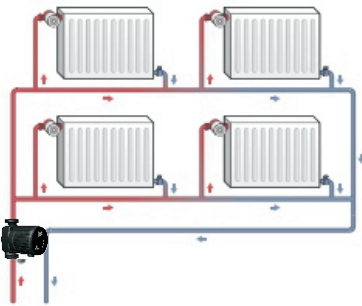

Figure2 Single pipe heating system

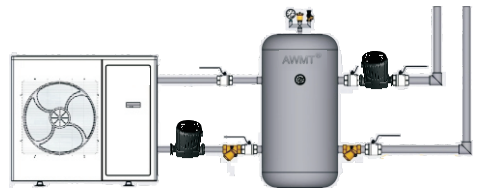

Figure5 Dual heating and cooling supply system

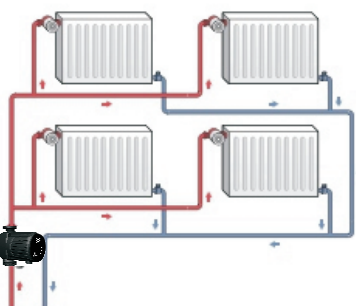

Figure3 Double pipe heating system

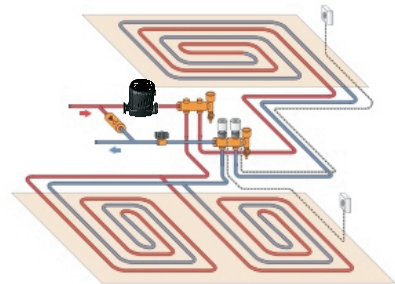

Figure4 Underfloor heating system

PUMPING LIQUID

The pump is suitable for the following media:

- ★ Clean, thin, non-corrosive, non-explosive liquid, no solid particles or fibers.
- ★ Mineral oil-free cooling liquid.
- ★ Circulating water (tap water), hardness does not exceed 14° dH, temperature does not exceed 65 °C, the peak temperature in shorttime does not exceed 95°C. (Dissolved calcium in tap water must not form scale).
- ★ Softened water

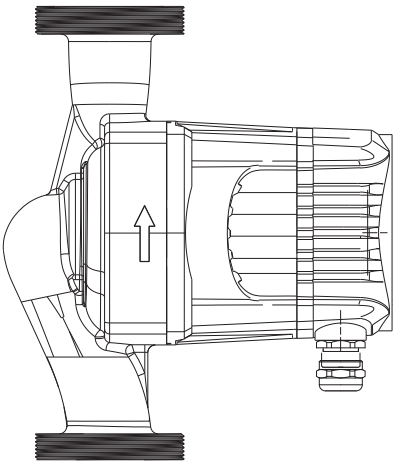

Figure 6 **Side chart**

The kinematic viscosity of water at 20°C $\nu = 1 \text{ mm}^2/\text{s}$ (1cst). When the viscosity of the medium is too high, the hydraulic performance of the pump will somewhat decrease. For example, at 20°C, the viscosity of 50% glycol solution is 10mm²/s (10cst), water Pump performance decreases by about 15%.

Do not use additives that will affect the function of the pump.

When selecting the pump, it should be considered whether the viscosity of the pumped liquid is within the working range of the pump.

CONTROL OF HEATING SYSTEM

The daily thermal requirements of the building will vary with the change of the external temperature, solar radiation, the people in the building and the use of electronics standby.

In order to adapt to this change, the heat supply of the building also needs to be constantly changed, and in daily life, people may adjust by adjusting or closing the heat balance valve. Generally do not control the speed of the pump, when the demand of heat is reduced, the head may be too high. This could have the following consequences.

- Excessive energy consumption;
- The control effect of the system becomes worse;
- Radiator balance valve or similar device produces noise.

This pump Automatically adjusts the pump with out the need of additional accessories to adapt pump performance to thermal requirements.

PROPORTIONAL MODE

The built-in proportional mode is particularly suitable for

- Heating and cooling system.
- Dual supply secondary system.

The proportional mode (factory preset) automatically adjusts the pump performance according to the cooling and heating requirements, such as the changes in system size or cooling and heat requirements. The performance adjustment effect is optimized over time. For a pump initial installed, the adjustment effect is not the best.

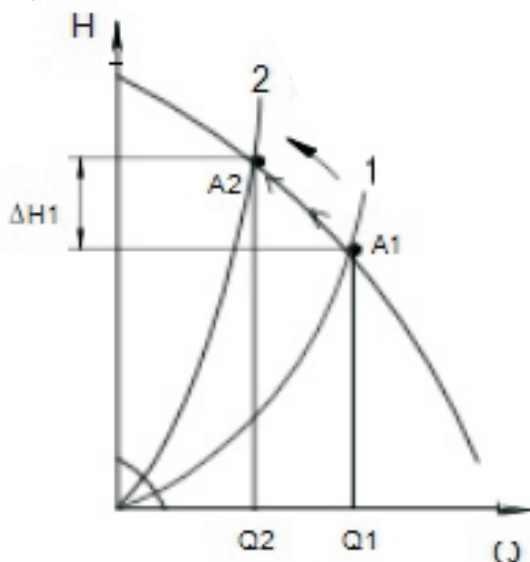

When power is cutoff, the pump stores the proportional mode parameters in internal memory, and when power is restored, the performance parameters are also recovered.

Figure 7

Constant speed pump

OPERATION

The Intelligent self-adaption permanent magnet variable frequency shielded circulating pump can automatically control its own performance and adjust the pump performance to match the system heat demand.

- Adjust pump performance to match changes in system performance 24 hours a day.
- In the proportional mode, the pump is in the proportional pressure differential control mode.

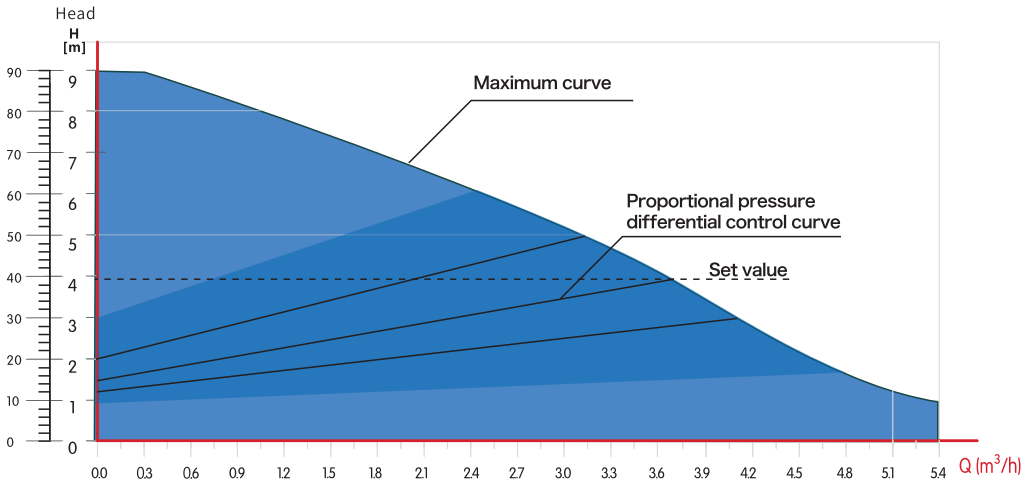

Figure 8 Range of proportional regulation

The proportional mode is different from other control functions in that it adaptively moves and adjusts the pump performance within a range. The shadow range indicated in the figure is the moving range of the proportional differential pressure curve.

CONTROL ADVANTAGE

Pressure control in this pump is closely integrated with flow (proportional pressure control and constant pressure control). In contrast to the constant speed pump, the proportional differential pressure control in this pump will also reduce the pressure difference between the two ends of the pump when the heat demand is reduced.

When the demand for heat and cold is reduced, such as solar irradiation increased, the radiator regulating valve will be turned down, and the resistance of the system will be increased for the constant speed pump. For example, A1 to A2 when using a constant speed pump, System pressure will increase $\Delta H1A_0$.

If Intelligent self-adaption permanent magnet variable frequency shielded circulating pump is used in the system, the pressure is relatively reduced $\Delta H2$. Thus reduces energy consumption. See Figure 9

With a constant speed pump in the system, the increase in pressure usually causes the fluid to make noise in the radiator balance valve. This noise can be greatly reduced by using Intelligent self-adaption permanent magnet variable frequency shielded circulating pump.

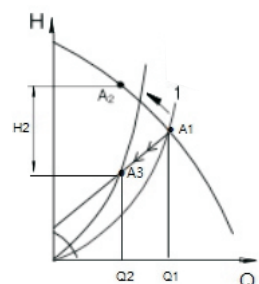

Figure 9 Pump operating in proportional differential pressure control mode

AUTOMATIC NIGHT SPEED REDUCTION

This pump has an optional night mode, which can be enabled by pushing the [Set button + Down button] on the panel for 3 seconds.

Factory Settings: Not enabled

Note: When the pump is set to I, II, III in night mode, it will automatically decrease the speed in the set gear at night. When the night mode is turned on, the pump will need to manually switch between the night mode and the normal operating mode.

FEATURE

The pump must be installed on the pipeline when the automatic nighttime speed reduction function is enabled in the system, and the switch between normal operation and nighttime speed reduction working mode is determined by the pressure of the pipeline.

When the pipeline pressure exceeds the corresponding pressure of the set gear, the pump automatically switches to the automatic speed reduction mode at night, reducing by 10% per hour. The rate of temperature reduction must be at least 1°C per minute. When the pipe temperature rises by about 10°C, the pump switches back to normal operation mode, which does not depend on the time.

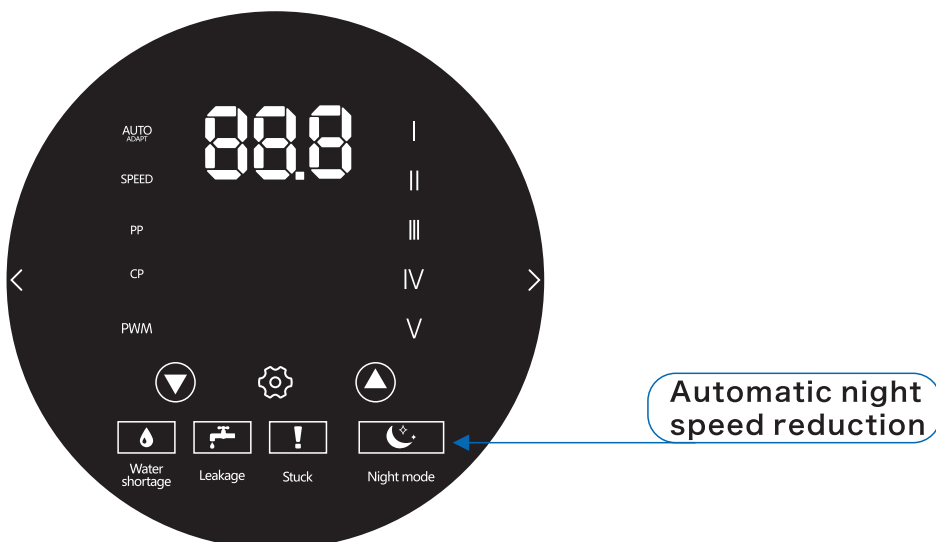

Figure 10 Night mode layout location

This pump uses a shielded rotor, and the pump and motor are combined as one. Instead of shaft seals, only 2 gaskets are used. Bearings are lubricated by pumping medium.

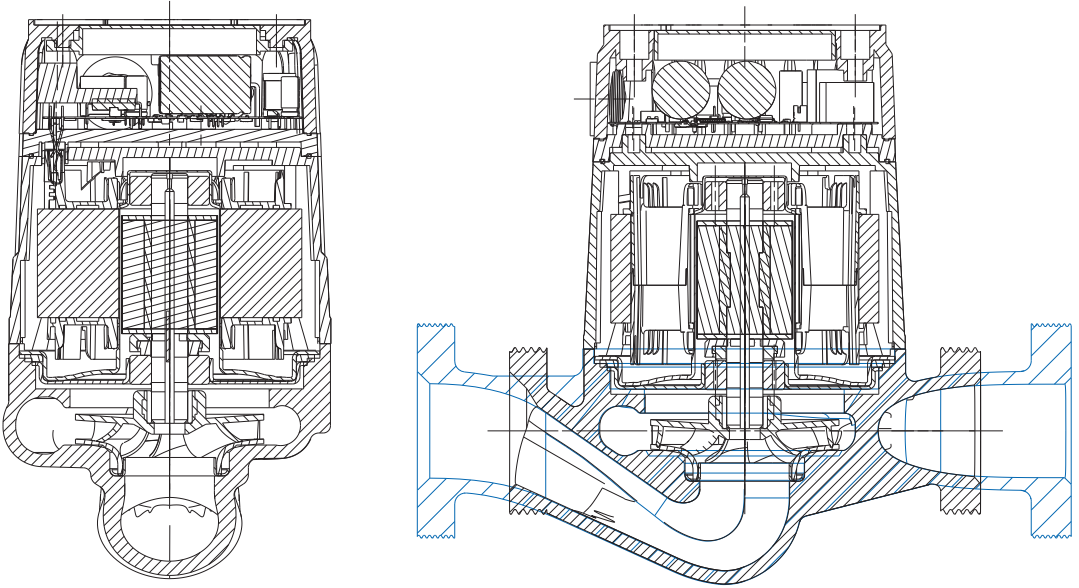

Figure 11 Planing plan

The pump consists of the following parts:

- Built-in AUTO ADAPT control
- Built-in proportional pressure control
- Built-in constant pressure control
- Different constant curve (constant speed) control
- Frequency inverter
- Permanent magnet rotor/compact stator motor
- Real-time display of actual pump power consumption wattage (built-in) or actual flow m^3/h (shown as min division $0.1 \text{m}^3/\text{h}$)
- Ceramic shaft and radial bearing
- Carbon thrust bearing
- Composite material impeller
- Cast iron or stainless steel pump body
- Compact design of pump integrated with control box and panel
- Easy to find faults when they fail



Figure 12 Parts drawing

MOTOR AND CONTROL BOX

The motor is a four-pole brushless synchronous permanent magnet motor, and the pump controller is located in the control box, which is integrated with the pump and the motor. The control panel is located on the front of the control box,

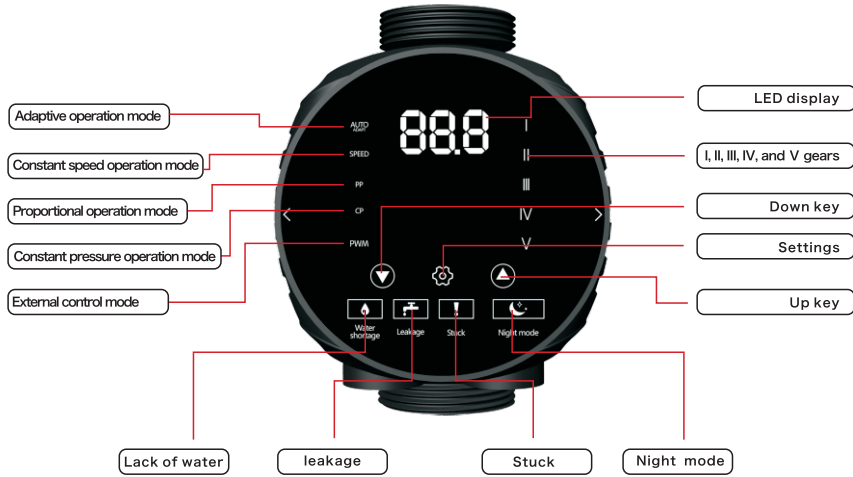











Figure 13 Key position

OPERATION PANEL

<p>AUTO ADAPT</p>	<p>Automatic adaptation mode, the performance of the pump can be automatically adjusted in a specific range according to the requirements of the system scale</p>	
<p>SPEED</p>	<p>I II III IV V</p>	<p>The pump will operate at a constant speed with a constant performance curve. No matter what the working conditions</p> <p>The pump is set to operate at maximum performance in gear I. The pump is set to operate at maximum performance in gear II. The pump is set to operate at maximum performance in gear III. The pump is set to operate at maximum performance in gear IV. The pump is set to operate at maximum performance in gear V.</p>
<p>PP</p>	<p>I II III IV V</p>	<p>Depending on the actual requirements of the system, the operating point of the pump moves up and down the lowest proportional differential pressure curve. Depending on the actual needs of the system, the operating point of the pump moves up and down the second gear proportional differential pressure curve. Depending on the actual requirements of the system, the operating point of the pump moves up and down the three-speed proportional differential pressure curve. Depending on the actual needs of the system, the operating point of the pump moves up and down the four-speed proportional differential pressure curve. Depending on the actual needs of the system, the operating point of the pump moves up and down the five-speed proportional differential pressure curve.</p>
<p>CP</p>	<p>I II III IV V</p>	<p>First gear constant pressure curve. Second gear constant pressure curve. Third gear constant pressure curve. Fourth gear constant pressure curve. Fifth gear constant pressure curve.</p> <p>Depending on the heat demand, the working point of the pump moves horizontally left and right, and the head (pressure) remains unchanged, independent of the heat demand.</p>

	When a voltage is connected to the PWM, the system automatically enters the PWM mode. Other functions cannot be configured. The pump enters configurable condition automatically when PWM mode is cutoff.	
	Lack of water	
	leakage	
	Stuck	
	Night pattern	
	Adjust the speeds	Tap and hold  key+ 
	Set the mode change and clear the alarm.	Push 3 seconds to switch the pump on and off

The display starts when the power supply is connected. During operating the displayer displays the actual power wattage. Accuracy: $\pm 5\%$

FAULT INDICATION

Faults that cause the pump to operate improperly, such as a stuck rotor, can display a fault code on the display device.

The following fault codes are displayed:

★ Rotor stuck	E1	① Check whether the motor is short-circuited and whether the wrong motor is matched. ② The driver is damaged. Replace the circuit board.
★ The controller is short circuited	E2	① Check whether the motor is short-circuited and whether the wrong motor is matched. ② The driver is damaged. Replace the circuit board.
★ The input voltage is too high	E3	Check whether the external input voltage is too high
★ The input voltage is too low	E4	Check whether the external input voltage is too low
★ Stuck	E5	Please try to turn the impeller to see if it is stuck
★ Lack of water	E6	Check if it is lack of water
★ Phase missing	E7	Check whether the motor wire is loose and not connected properly
★ The controller overheats	E8	When the controller drops to a safe temperature, it will automatically restart
★ The temperature detection is faulty	E9	Replace circuit board
★ The circuit board is faulty	E10	Replace circuit board
★ Startup failure	E11	Check if the motor has phase missing, and if the impeller stuck
★ leakage	E12	Check whether pipes leak

MOUNTING DIMENSION SPECIFICATION

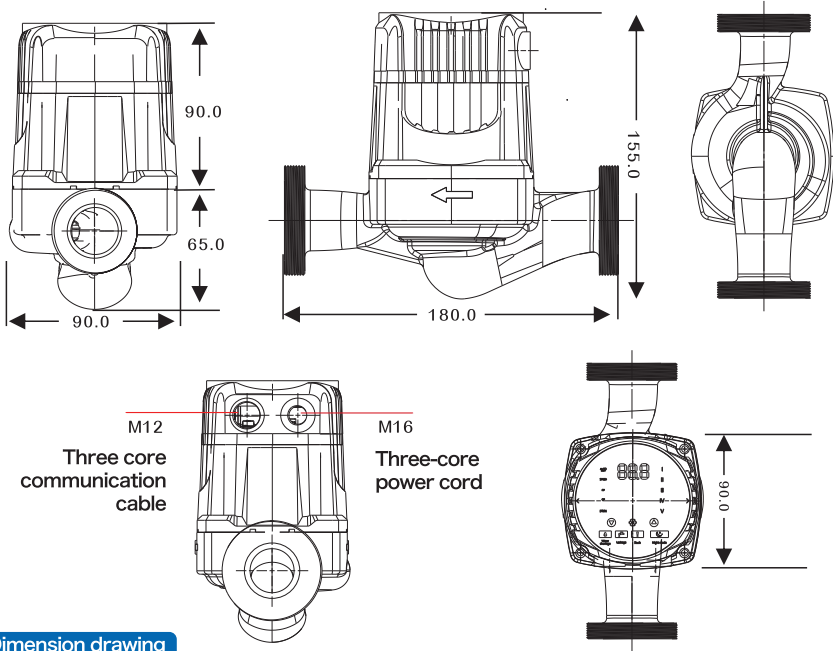
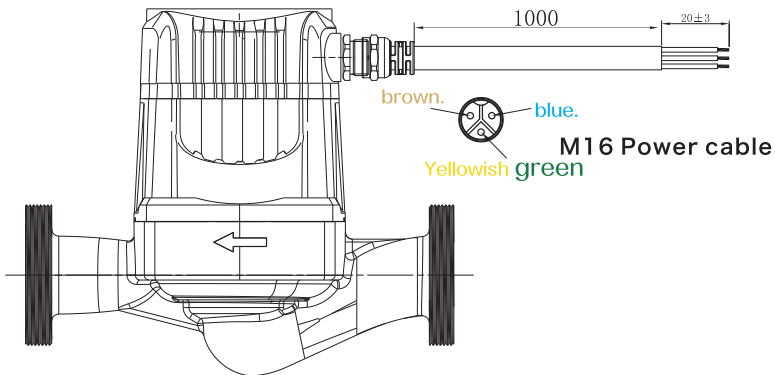

Figure 14 Dimension drawing

DESCRIPTION OF POWER AND COMMUNICATION CABLES

The plug has cable fixing and circlip structure to ensure normal power connection.



Supply voltage: 1 x 230 V [+ 10 % /- 15 %], 50 Hz.



Before use, the pump must be reliably grounded, and the three-core power plug must not be altered to prevent the risk of leakage in case of leakage, and corresponding security measures such as leakage circuit breakers or electric shock guards must be installed to ensure safety.

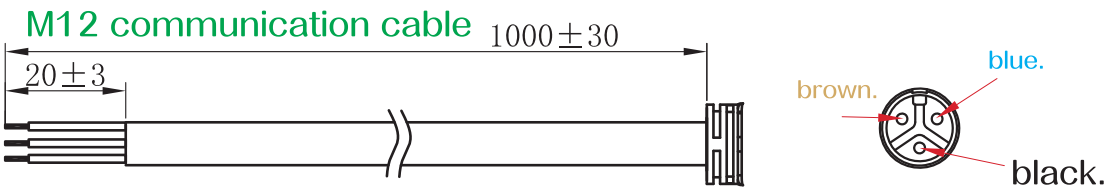

The circulating pump is controlled externally by PWM signal, or internally by frequency converter.

Therefore, the circulating pump should not be used in conjunction with other external speed controls, as this would cause a change in the input voltage, such as tangential or pulse cascade control.

INSTALLATION

In most installation situations, the pump only needs to be mechanically installed and then powered on.

The motor shaft must be kept horizontal when the pump is installed.

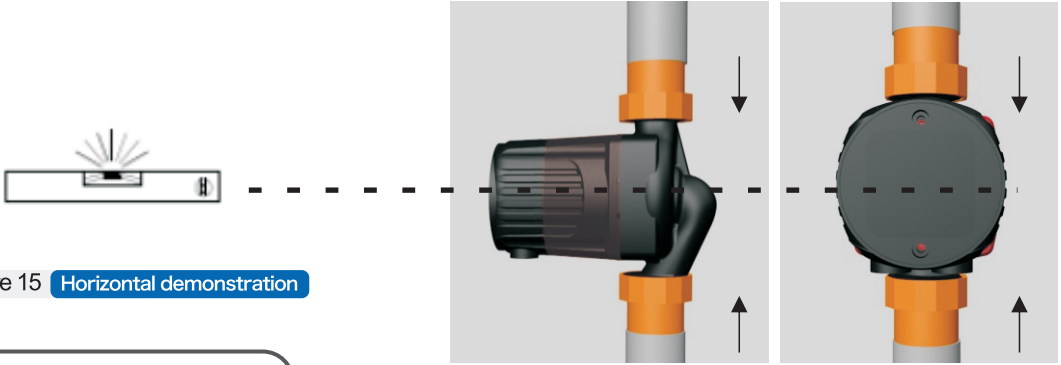

Figure 15 Horizontal demonstration

ELECTRICAL DATA

Power supply voltage	1x230V±10%, 50/60 Hz, PE.
Motor protection	The pump does not require external motor protection
Level of protection	Ip44
Insulation class	F
Relative air humidity	Up to 95%
Ambient temperature	0°C to +40°C
Temperature rating	TF110, CEN 335-2-51
EMC (Electromagnetic Compatibility)	2004/108/EC Criteria used: EN55014-1:2006 and EN 55014-2:1997.
Noise grade	≤35dB(A)

ACTIVATE

The pump must be started only after the system is fully filled with liquid and exhaust air, and the inlet pressure of the pump must reach the required minimum inlet pressure. The system cannot be air-exhausted with the pump. The pump itself be automatically air-exhausted, so there is no need to exhaust the pump before using.

SYSTEM PRESSURE

Pn10: The highest 1.0MPa(10bar)



LIQUID TEMPERATURE

Cast iron pump: +2°C至+110°C。

Stainless steel pump in circulating water (medium containing calcium and magnesium ions) system:+15°C to +65°C.

When the pump is used in a circulating water system, we recommend maintaining the circulating water temperature between 45 and 65 °Cto eliminate calcium scaling (excessive temperature).

To avoid condensation in the control box or inside the motor, it is necessary to ensure that the temperature of the pumping medium is always higher than the ambient temperature. See the following table:

Ambient temperature 【 °C 】	Liquid temperature	
	Minimum 【 °C 】	Max 【 °C 】
0	2	95
10	10	95
20	20	95
30	30	95
35	35	90
40	40	70

When installing, ensuring that the power plug is straight down, the pump can work in the environment where the ambient temperature is higher than the medium temperature.

INLET PRESSURE

In order to prevent cavitation noise and avoid damage to the pump bearing, the minimum pressure value of the pump suction port is shown below.

Liquid temperature	75°C	90°C	110°C
Inlet pressure	0.5m Static pressure	2.8m Static pressure	10.8m Static pressure
	0.005MPa	0.028MPa	0.108MPa
	0.05bar	0.28bar	1.08bar

FACTORY DEFAULT SETTINGS

The factory Settings are listed below.

The Settings shown are suitable for most household situations

Pump type	Settings	Automatic night speed reduction
	AUTO ADAPT	Automatic adaptation mode

REPAIR

Dangerous electric shock



- Death or serious bodily injury
- Before performing maintenance on the pump, first turn off the power. Make sure the power won't be accidentally switched on.
- Note that the capacitor will remain electrification for 30 seconds even after cutoff.

Dangerous electric shock



- Death or serious bodily injury
- Before removing the complete pump set, turn off the power at least 5 minutes before starting work and ensure that the power cannot be turned on again.

Dangerous electric shock



- Death or serious bodily injury
- When running in reverse, the pump acts as a generator and creates a dangerous induced voltage on the motor terminals.
- Close the stop valve to prevent liquid backflow.

warn



Strong magnetic field in rotor area

There's a risk of death for patients with pacemakers. Maintain a safe distance of at least 0.3 m during disassembly.

Caution



High temperature surface

For mild or moderate personal injury, allow the pump housing to cool to the surrounding temperature before starting work.



All maintenance work must be done by trained technicians.



Before removing the water pump, empty the system or close the isolation valves at both ends of the water pump.

Maintenance

The pump is maintenance-free, but sometimes it may be necessary to disassemble or open the pump, such as when the pump is clogged with impurities by unscrewing the front hex screw to disassemble.

1. Unscrew the hex socket screws on the front of the pump head.
2. Disassemble the pump with a screwdriver.

Clean

If you need to remove impurities from the impeller or pump housing, follow these steps:

1. Drain the system or close the isolation valve.
2. Remove the screws securing the pump head.
3. Check the impeller and pump casing and remove impurities.
4. Place the pump head in the desired position, screw and tighten it.

TROUBLESHOOTING

Troubles	Reason	Troubleshooting
Pump not running Power off	The system shuts down	Check the system controller.
	A fuse has ruptured in the facility	Replace the fuse.
	Circuit breaker trip	Check the power connection and turn on the circuit breaker.
	The power supply is faulty	Check the power supply.
Pump not running General power supply	Controller off	Check the controller and its Settings
	The pump is clogged with impurities	Remove impurities, unscrew the release screw on the front of the pump head, and unlock the pump from the front of the control box with a screwdriver. Be careful of hot water ejecting.
	There's something wrong with the pump	Replace the Pump
The pump operates at maximum speed and cannot be controlled	The signal cable has no signal	Check whether the cable is connected to the controller. If yes, replace the cable.
There's noise in the system	There's air in the system	Exhaust air in the system
	Too much pressure difference	Reduce pump performance on pump or external controller
There is noise in the pump	There is air in the pump	Let the pump run and it will empty itself over time.
	Inlet pressure is too low	Increase system pressure or check the amount of air in the expansion box, if any expansion box is installed.
underflow	Pump performance is low	Check external controller and pump Settings.
	Hydraulic system shut down or system pressure is insufficient	Check check valves and filters. Increase system pressure.



Parameter table of each model

Mode	Max power (W)	Minimum power (W)	Max.Flow (m ³ /h)	Max.Head (m)	Diameter of thread
BP-25-80-130	80w/1A	9w/0.05A	5.4	8	1 ½"
BP-25-80-180	80w/1A	9w/0.05A	5.4	8	1 ½"
BP-32-80-130	80w/1A	9w/0.05A	6	8	2"
BP-32-80-180	80w/1A	9w/0.05A	6	8	2"
BP-25-100-130	140w/1.47A	9w/0.19A	7.2	10	1 ½"
BP-25-100-180	140w/1.47A	9w/0.19A	7.2	10	1 ½"
BP-32-100-130	140w/1.47A	9w/0.19A	7.8	10	2"
BP-32-100-180	140w/1.47A	9w/0.19A	7.8	10	2"

Constant pressure performance diagram

CURVE CONDITION

The following description applies to the performance in the parameter table:

- Test liquid: water without gas.
- The performance is suitable for a density of $\rho=983.2\text{kg/m}^3$ and a liquid temperature of $+60^\circ\text{C}$.
- All parameters represent average values only and are not considered guaranteed parameters.
- If there are specific requirements for minimum performance, they need to be tested separately
-
- The performance is suitable for the kinematic viscosity of $\nu=0.474\text{mm}^2/\text{s}$ (0.474cSt).
- The conversion between head $H[\text{m}]$ and pressure $p[\text{kPa}]$ is only applicable to liquids with a density of $\rho=1000\text{kg/m}^3$.
- For other densities of liquids, such as hot water, the output pressure is proportional to the density.





iNERGY[®]

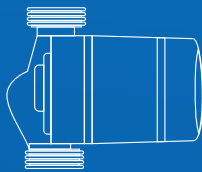

100% COPPER WIRE
THERMAL PROTECT